

THIS DRAWING IS UNPUBLISHED. RELEASED FOR PUBLICATION
 © COPYRIGHT BY TYCO ELECTRONICS CORPORATION. ALL RIGHTS RESERVED.

LOC	DIST	REVISIONS					
FT	0	P	LTR	DESCRIPTION	DATE	DWN	APVD
			D1	REVISED PER ECO-05-675	8/30/05	SS	SH

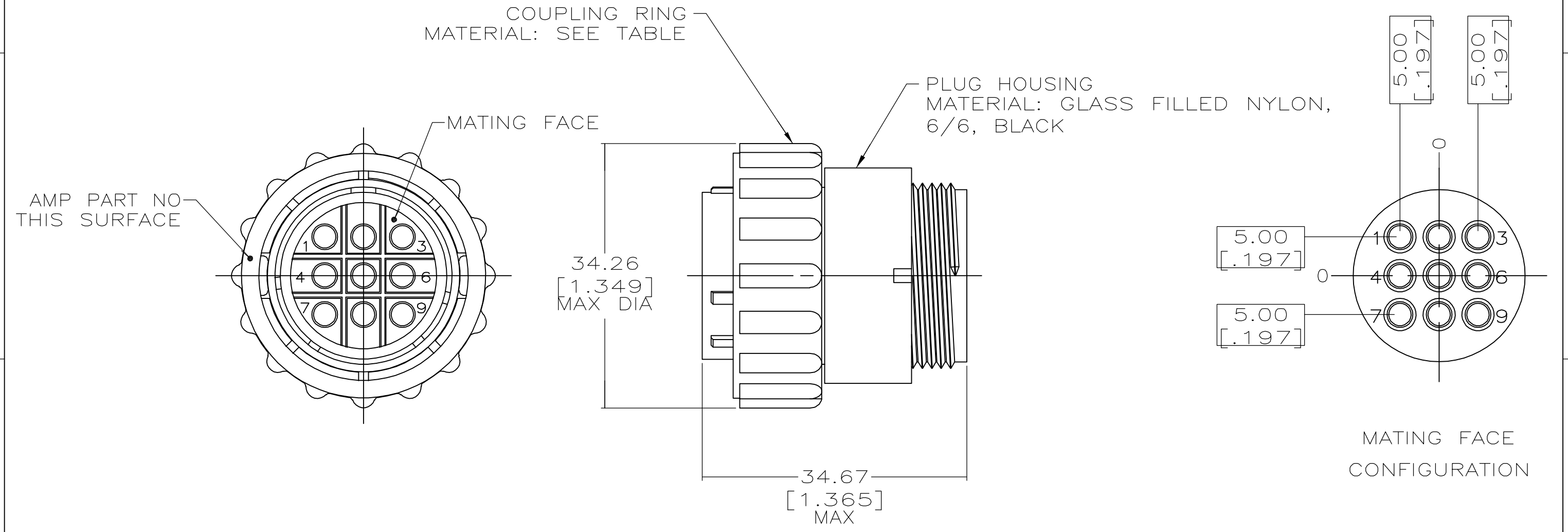

- CONTACT CAVITIES IDENTIFIED BY CHARACTERS ON FRONT AND REAR FACES OF CONNECTOR.
- THIS PART WILL ACCEPT 9 MULTIMATE PIN CONTACTS.

DIE CAST ZINC	211768-2
POLYESTER, BLACK	211768-1
COUPLING RING MATERIAL	PART NUMBER

THIS DRAWING IS A CONTROLLED DOCUMENT.		DWN	K.FOLTZ	06/29/94	Tyco Electronics Corporation Harrisburg, PA 17105-3608					
DIMENSIONS: mm [INCHES]		CHK	R.STONE	06/30/94						
TOLERANCES UNLESS OTHERWISE SPECIFIED: 0 PLC ± - 1 PLC ± - 2 PLC ± - 3 PLC ± - 4 PLC ± - ANGLES ± -		APVD	-	-	NAME		PLUG ASSY, SPECIAL VDE, CLASS A, REVERSE SEX, ARRANGEMENT 17-9, CPC			
		PRODUCT SPEC	-	-	SIZE	CAGE CODE		DRAWING NO	RESTRICTED TO	
MATERIAL		WEIGHT	-	-	A3	00779	C=211768	-		
CUSTOMER DRAWING					SCALE	2:1	SHEET	1 OF 1	REV	D1